

Relativistic heavy ion physics 1996-2007

Czech activities

A.Kugler, NPI ASCR, Řež

- **Two Arms Photon Spectrometer** since 1990
KVI (1996-7), GANIL (1998), analysis up to 2003
- **High Acceptance Di-Electron Spectrometer** at GSI
TOF installation (1997-9), HADES operates since 2001,
FW installation (2006-7)
- **Compressed Baryonic Matter** at GSI
R&D since 2004, has to operate from 2013 at SIS300

Physics

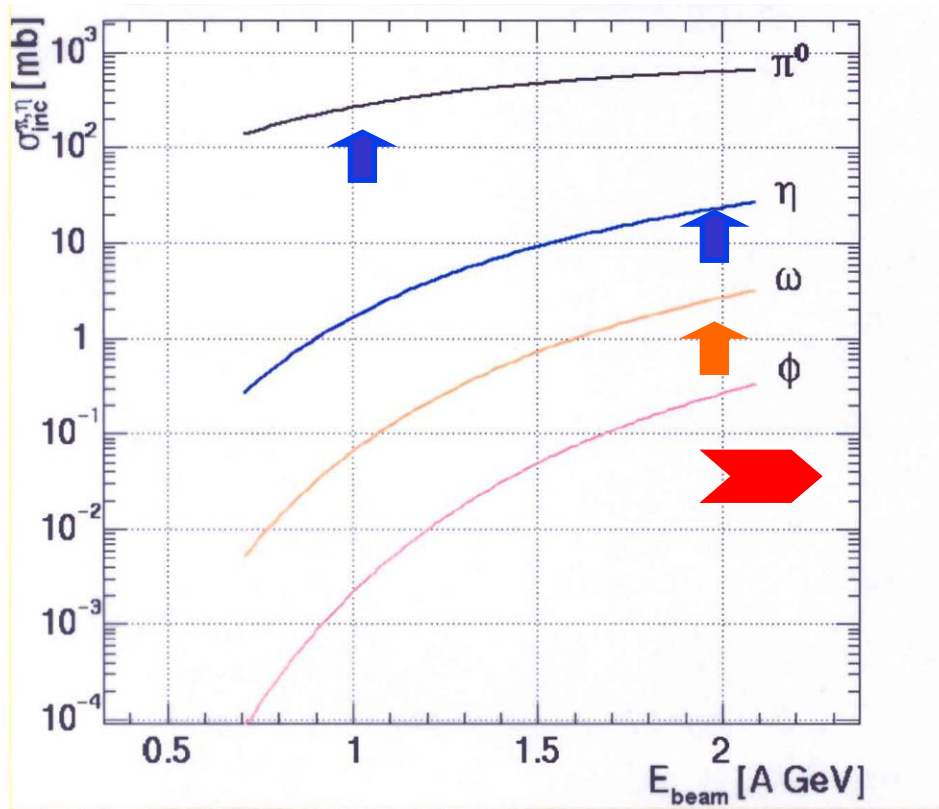

- TAPS $\pi^0, \eta \rightarrow 2\gamma$
 - experiments before 1999
 - analysis up to 2003
 - squeeze-out
- HADES $\omega, \rho \rightarrow e^+ + e^-$
 - build up 1999-2001
 - experiment 2002-9
 - in medium particle properties change?
- HADES@8GeV
 $\Phi, \omega, \rho \rightarrow e^+ + e^-$
 - experiment starts 2010 (SIS100)
- CBM $D^0, D^+ \rightarrow e^+ + e^-$
 - R&D starts 2004
 - build up before 2012
 - runs after 2013 (SIS300)

People

$$M_{\gamma\gamma} = [2E_1E_2(1 - \cos \Theta_{12})]^{1/2}$$

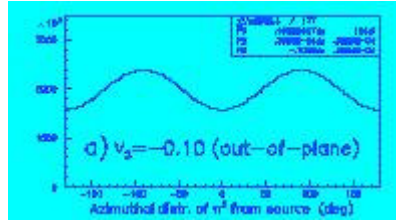
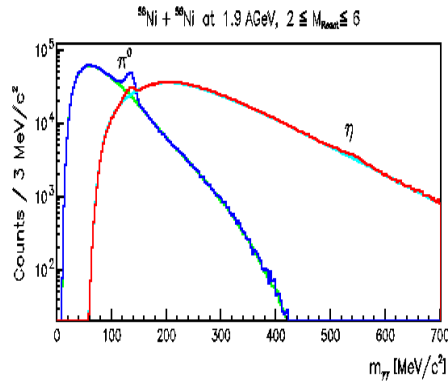

$$N(\varphi) = N_0 [1 + 2v_1 \cos(\varphi) + 2v_2 \cos(2\varphi)]$$

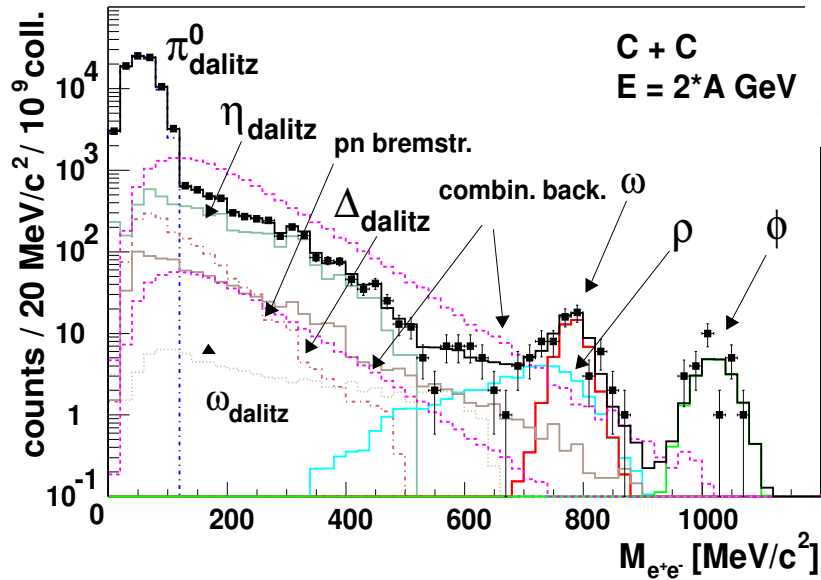
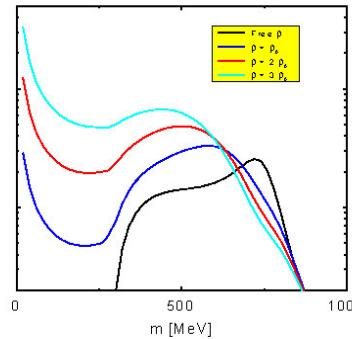

Relativistic heavy ion physics group

A.Kugler, P.Tlustý,
V.Wagner

TAPS

Arkadii Taranenko

- PhD 2001
- up to 2002
- Radek Pleskač
- PhD 2003

HADES

- Vladimír Pospíšil
 - diploma 2004
- Filip Křížek
 - PhD 2007?
- Antonín Krása
- CBM
- D. Adamová

TAPS, experiment

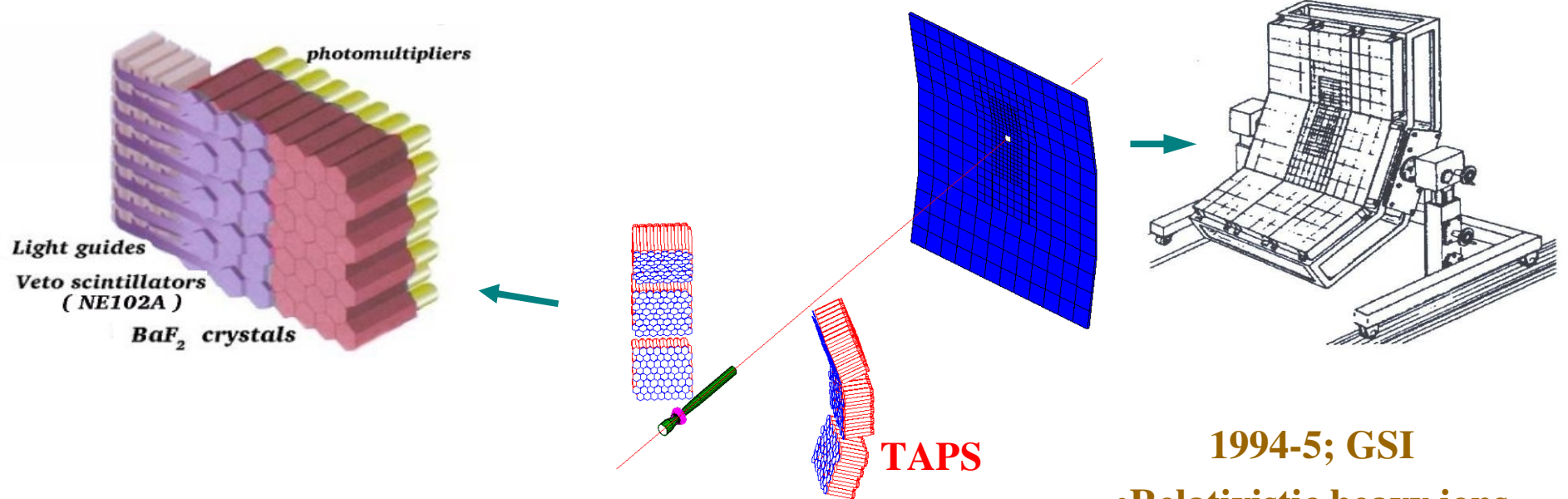

1994-5; GSI

- Relativistic heavy ions
- pions and eta mesons

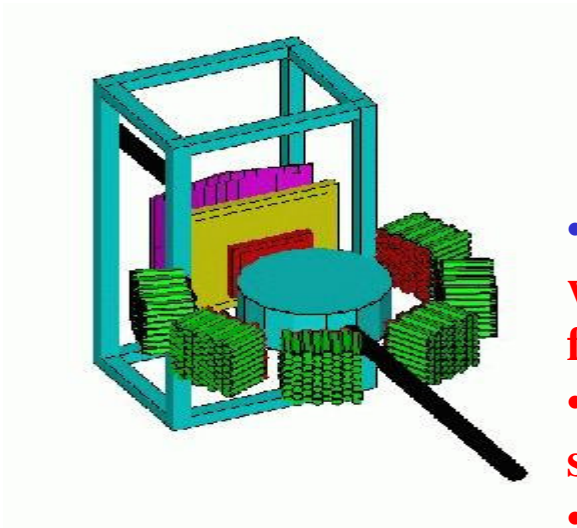

1996-7; KVI

- polarized proton beam with energy 190 MeV from AGOR
- brehmstrahlung studied
- neutron emission

1992,1998; GANIL

- subthreshold pion production in heavy ion collisions
- hard photons emission in heavy ion collisions

TAPS results

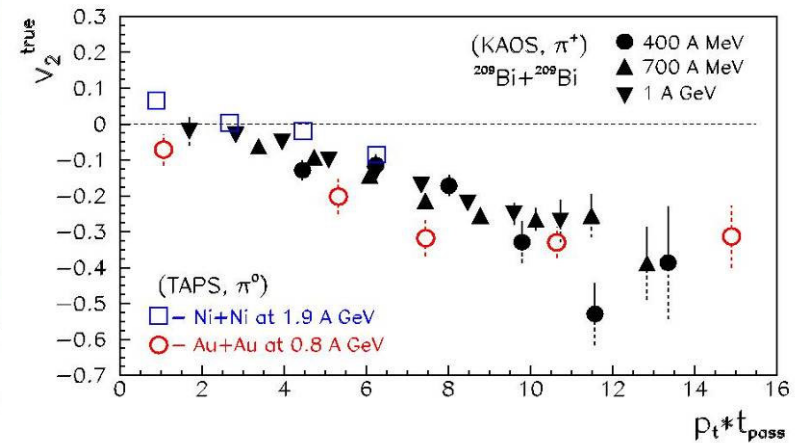
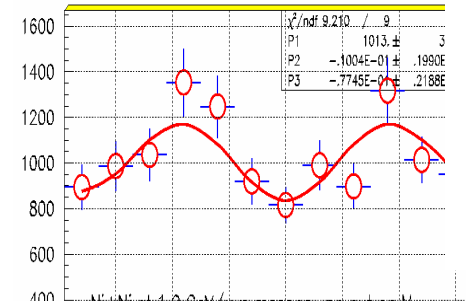
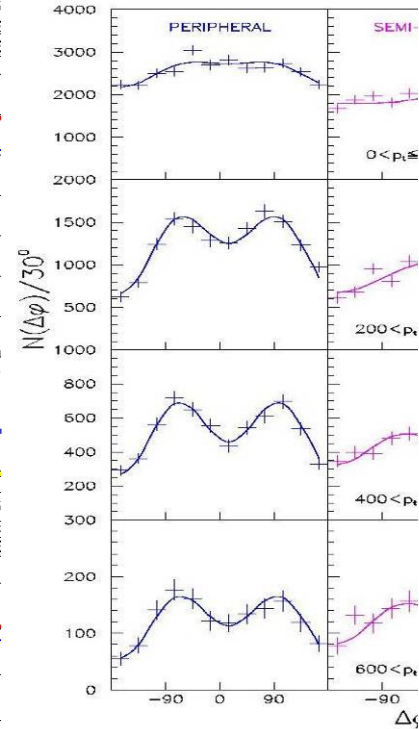
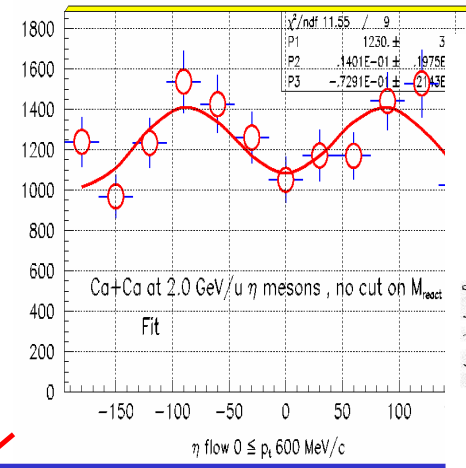
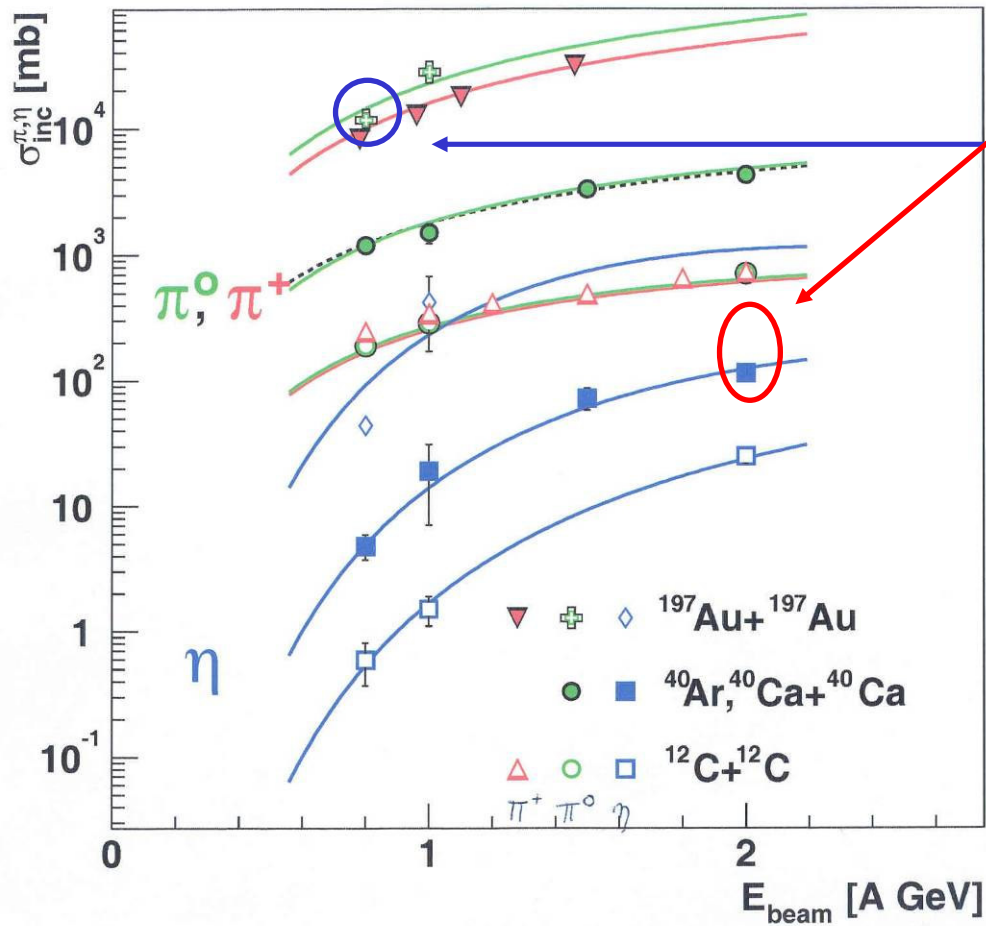

TAPS, papers in referred journals 1996-2000

Publikace

- T. Matulewicz,... A.Kugler, V.Wagner, P.Tlusty et al. *OBSERVATION OF DELTA+ --> P PI0 DECAY IN HEAVY ION COLLISIONS*. Eur.Phys.J.A9:69-72,2000.
- M.Hoefman,... A.Kugler, V.Wagner, P.Tlusty et al. *Coherent Bremsstrahlung in the alpha + p system at 50 MeV/nucleon*. Phys.Rev.Lett.85 (2000) pp.1404-1407.
- Taranenko A, Kugler A: Elliptic flow of eta and pi(o) mesons in heavy-ion collisions at 2 A GeV, CZECHOSLOVAK JOURNAL OF PHYSICS 50: 139-166, Suppl. 4 2000
- H.Huisman,...A.Kugler and V.Wagner, High-Precision Proton-Proton Bremstrahlung Measurements below the Pion-Production Threshold, Phys.Rev.Lett., Vol.83., No.20., 1999, 4017-4020.
- .Martinez,...A.Kugler, P.Tlusty, V.Wagner et al., *Photon production in heavy-ion collisions close to the pion threshold*, Phys.Lett. B 461, 1999, 28-33.
- G.Martinez,...A.Kugler, P.Tlusty, V.Wagner et al., *Deep-Subthreshold η and π^0 Production Probing Pion Dynamics in the Reaction Ar+Ca at 180 A MeV*, Phys.Rev.Lett., Vol.83, No.8., 1999, 1538-1541.
- J.G.Messchendorp,... A.Kugler and V.Wagner, *Exclusive Measurements of Virtual Bremsstrahlung in Proton-Proton Scattering at 190 MeV*, Phys.Rev.Lett., Vol.82, 1999, 2649-52.
- A.Marín,...A.Kugler,...R.Pleskac,..P.Tlusty,...V.Wagner..., Detection of charged pions and protons in the segmented electromagnetic calorimeter TAPS, NIM A417, 1998, p. 137-149.
- J.G.Messchendorp,... A.Kugler,... V.Wagner, *Measurements of the virtual bremsstrahlung yields in p+p system*, Nucl.Phys., A631, 1998, 618c-621c.
- A.R.Wolf,...A.Kugler,...R.Pleskac,..P.Tlusty,...V.Wagner...*Multistep production of eta and hard pion mesons in subthreshold Au-Au Collisions*, Phys.Rev.Lett., Vol.80, 1998, page 5281-4.
- R.Averbeck, ...A.Kugler, ...R.Pleskac, ..P.Tlusty,V.Wagner et al.: *Production of pi0 and eta mesons in carbon-induced relativistic heavy-ion collisions*, Zeitschrift fur Phys. A 359 (1997) 65-73. A.Marin,..A.Kugler,R.Pleskac, P.Tlusty, V.Wagner et al.: *Exclusive pi0 and eta meson production in 40Ar+natCa at 800 A MeV* , Phys.lett. B409 (1997) 77-82.
- .Holzmann,...A.Kugler,...R.Pleskac,..P.Tlusty,...V.Wagner et al.: *Contribution of pi0 and eta Dalitz decays to the dilepton invariant-mass spectrum in 1A GeV heavy-ion collisions*, Phys.Rev. C56 (1997) 2920-23.
- A. Taranenko, P. Tlustý, A. Kugler, V. Wagner, R. Pleskač, S. Hlaváč, R.S. Simon: *The Study of Neutral Pion Azimuthal Distribution in 58Ni+58Ni Reaction at 2 GeV/nucleon*, Czech. Journal of Phys 47 (1997) 891-898.
- J.H.G. van Pol, ...A.Kugler,...et al.: *Importance of One- and Two-Body Dissipation at Intermediate Energies Studied by Hard Photons*, Phys. Rev. Lett. 76 (1996) 1425-1428

TAPS, papers in referred journals 2001...

Publikace

- N. Yahlali,..., A.Kugler et al.: *DEEP SUBTHRESHOLD PION PRODUCTION IN AR-36 + AU-197 COLLISIONS*. Nucl.Phys.A749:190-193,2005
- N. Yahlali,..., A.Kugler et al.: *TRANSVERSE MOMENTUM DISTRIBUTIONS OF NEUTRAL PIONS PRODUCED AT DEEP SUBTHRESHOLD ENERGIES*. Int.J.Mod.Phys.A20:609-611,2005
- van Goethem MJ, Apechetché L, Bacelar JCS, Delagrangé H, Diaz J, d'Enterria D, Hoefman M, Holzmann R, Huisman H, Kalantar-Nayestanaki N, Kugler A, Lohner H, Martínez G, Messchendorp JG, Ostendorf RW, Schadmand S, Siemssen RH, Simon RS, Schutz Y, Turrisi R, Volkerts M, Wagner V, Wilschut HW: *Suppression of soft nuclear bremsstrahlung in proton-nucleus collisions* PHYSICAL REVIEW LETTERS 88: (12) art. no.-122302 MAR 25 2002
- Sauvan E, ...Kugler A, ...Wagner V, : *Radiative proton capture on He-6 - art. no. 042501*, PHYSICAL REVIEW LETTERS 8704: (4) 2501-+ JUL 23 2001
- D.G. d'Enterria,... A.Kugler, V.Wagner, P.Tlusty et al. Evidence for Thermal Equilibration in Multifragmentation Reactions Probed with Bremsstrahlung Photons, Phys. Rev. Lett. 87, 022701 (2001)
- D.G. d'Enterria,... A.Kugler, V.Wagner, P.Tlusty et al. *THERMAL BREMSSTRAHLUNG PROBING THE THERMODYNAMICAL STATE OF MULTIFRAGMENTING SYSTEMS*. Nucl.Phys.A681:291-294,2001.

TAPS, conferences, workshops ...

Conferences, workshops

- RHIP97 school, 1997, Prague, A. Taranenko, *The Study of Neutral Pion Azimuthal Distribution in 58Ni+58Ni Reaction at 2 GeV/nucleon*
- A.Kugler, *FYZIKA SRÁŽEK TĚŽKÝCH IONTŮ -NOVÝ SMĚR JADERNÉ FYZIKY*, zvaná přednáška na 13. konferenci slovenských a českých fyziků, konané v dnech 23. až 26. srpna 1999 na Technickej univerzite vo Zvolene, zbornik prednasok, Zvolen, 1999, 48-51.
- TAPS workshop, 5-9 září 2001, Krzyze, Poland, A.Taranenko *Elliptic flow of mesons from SIS up to RHIC energies*
- INPC2001, 30 července - 3 srpna, 2001, Berkeley, USA, A.Kugler *Elliptic Flow of Mesons and Dynamic of Heavy Ion Collisions?*
- GRC2002, June 16-21, 2002, New London, USA, A.Kugler, *Elliptic flow*
- R.Pleskač, A.Kugler, P. Tlustý, V.Wagner, S.Hlaváč: *Heavy-Ion Collisions: The Study of Collective Flow of Neutral Mesons in Au+Au Reaction at 800 A MeV Sbornik 14 konf.českých a slov. Fyziků, Plzeň 2002*

PhD thesis

- Arkadij Taranenko (školitel Vladimír Wagner a Andrej Kugler), Doktorandská práce, MFF Universita Karlova, Praha, 18 května 2001. *Elliptic flow of eta and neutral pion mesons emitted in heavy-ion collisions at 2 A.GeV.*
- Radek Pleskač (školitel Andrej Kugler), Doktorandská práce, MFF Universita Karlova, Praha, 30 září 2003. *Experimentální studie produkce neutrálních mezonů v relativistických jaderných srážkách.*

The HADES collaboration

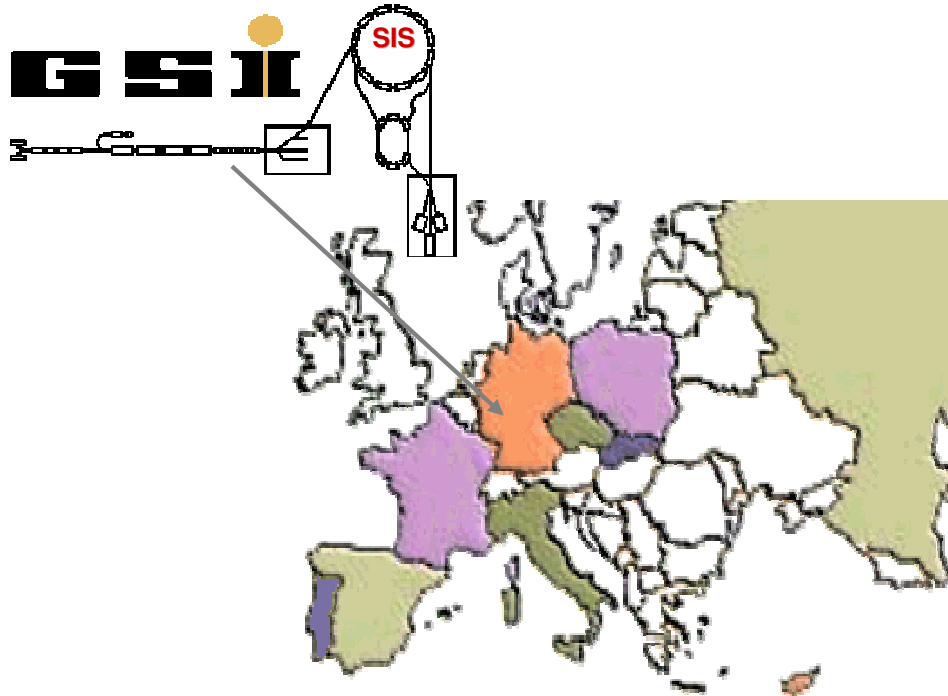

- **Bratislava (SAS, PI), Slovakia**
- Catania (INFN - LNS), Italy
- **Cracow (Univ.), Poland**
- Darmstadt (GSI), Germany
- Dresden (FZR), Germany
- Dubna (JINR), Russia
- Frankfurt (Univ.), Germany
- Giessen (Univ.), Germany
- Milano (INFN, Univ.), Italy
- Munich (TUM), Germany
- Moscow (ITEP, MEPHI, RAS), Russia
- Nicosia (Univ.), Cyprus
- Orsay (IPN), France
- **Rež (CAS, NPI), Czech Rep.**
- Sant. de Compostela (Univ.), Spain
- Valencia (Univ.), Spain
- Coimbra (Univ.), Portugal

HADES physics: In-medium modifications of hadron properties

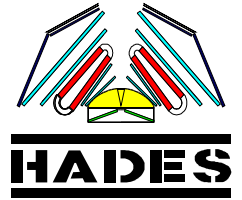

Hadron probes has to satisfy two basic conditions :

- Short life-time to decay inside compressed zone
- Decay channel with no final state interaction

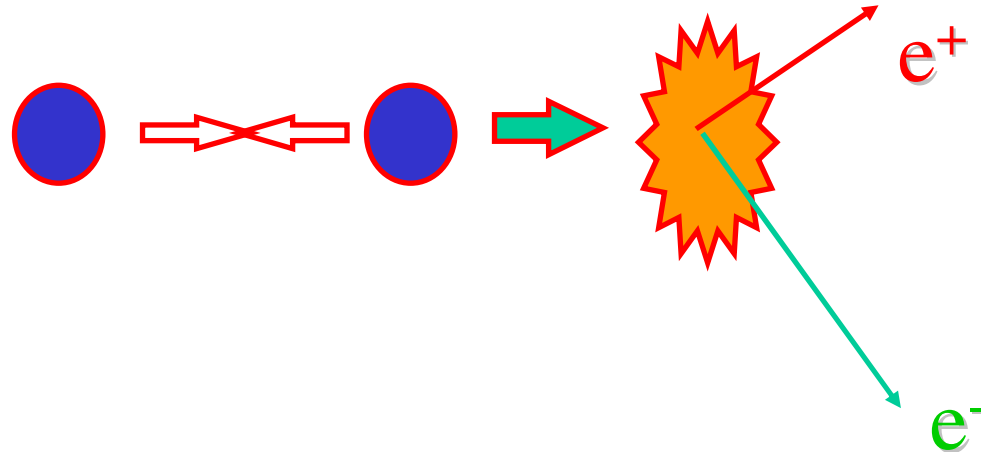

The hadron probes which satisfy both criteria are vector mesons (ρ , ω , ϕ) !!!

Mesons	Mass, MeV/c ²	Width, MeV/c ²	$c\tau$, fm	Dominant decay	Branching Ratio e^+e^-
ρ	768	152	1.3	$\pi^+ \pi^-$	$4.4 \cdot 10^{-5}$
ω	782	8.43	23.4	$\pi^+ \pi^- \pi^0$	$7.2 \cdot 10^{-5}$
ϕ	1019	4.43	44.4	$K^+ K^-$	$3 \cdot 10^{-5}$

HADES Detector

Features

- 10^6 events / s
- 45% geometrical acceptance
(2π in ϕ , $18^\circ < \vartheta < 85^\circ$)
- up to 200 charged particles
- 1% mass resolution

Components

MOMENTUM RECONSTRUCTION & PARTICLE IDENTIFICATION

- Mini Drift Chambers (**MDC**) in front and behind a superconducting toroid **magnet**
- Time of Flight (**TOF**) wall

LEPTON ENHANCEMENT

- Electromagnetic **Shower** detector

LEPTON IDENTIFICATION

- Hadron-blind Ring Imaging Cherenkov (**RICH**) detector

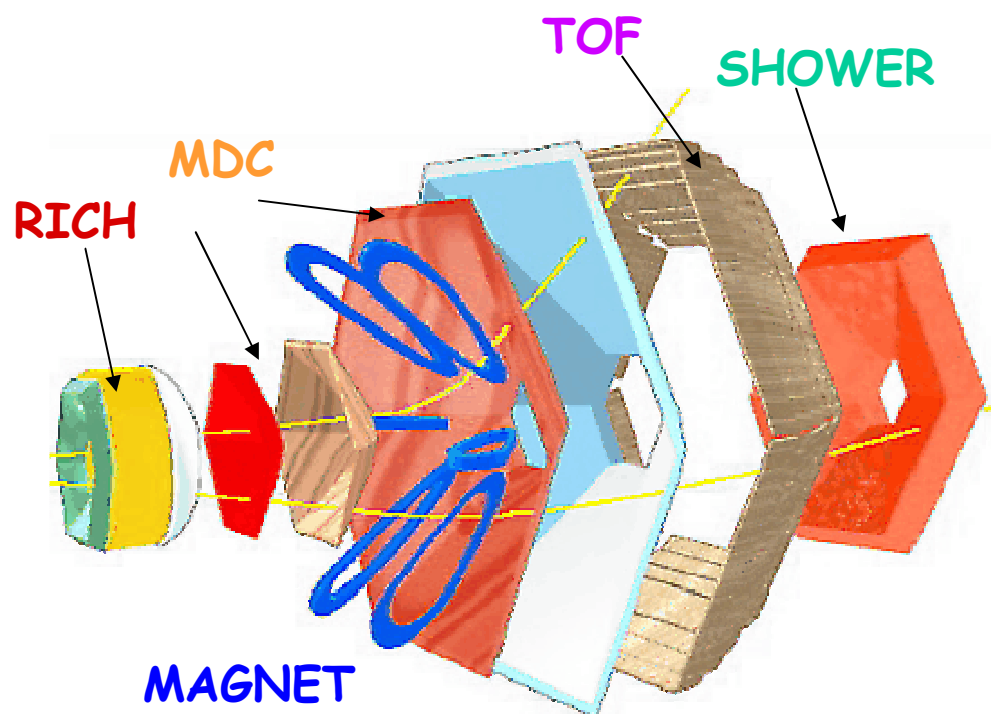

Lepton Analysis: Cuts

1. Geometry Rich – Track match: χ^2 cut

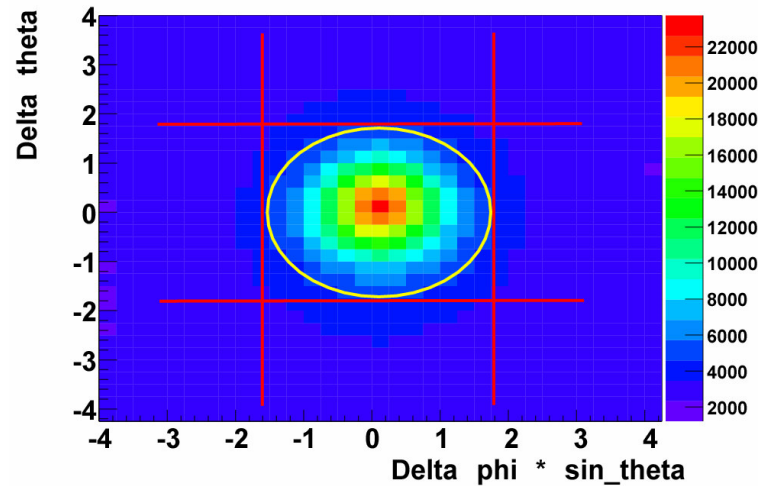

(particle's velocity) versus (particle's momenta * charge)

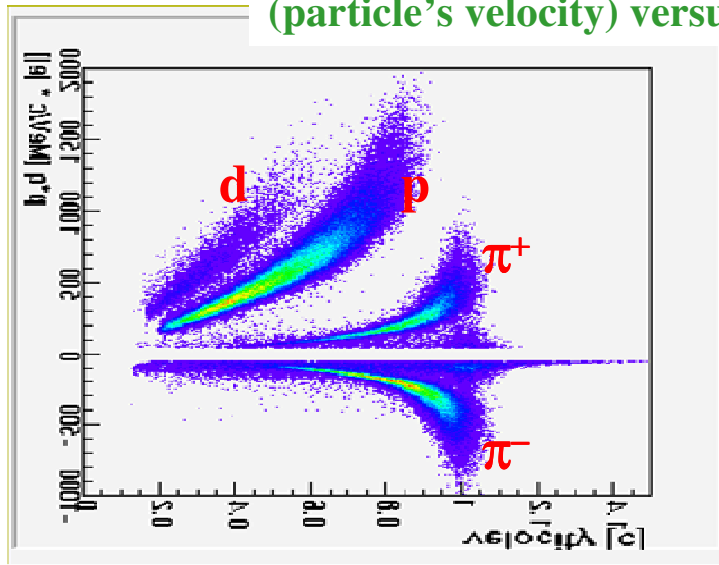

2. Time-of-Flight cut

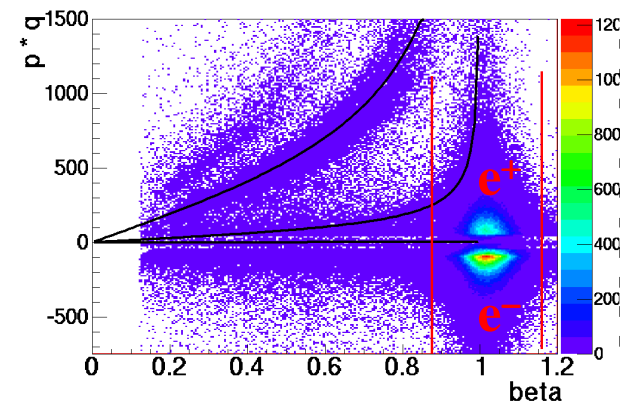

Time Of Flight detector

TOF wall covers $85^\circ > \Theta > 45^\circ$:

✓ 6 * 64 scint. Installed

✓ $TOF = (t_{\text{left}} + t_{\text{right}}) / 2$

$\delta t : 90 - 140 \text{ ps}$

✓ dE/dx measurement

✓ Tracking

$$x = v_g * (t_{\text{left}} - t_{\text{right}}) + x_{\text{right}}$$

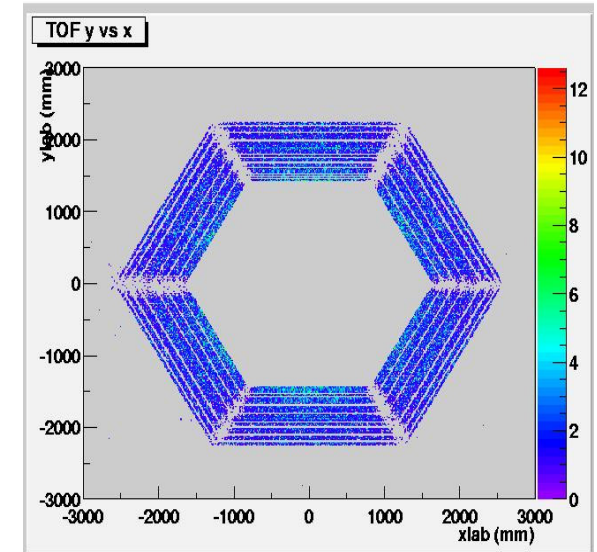
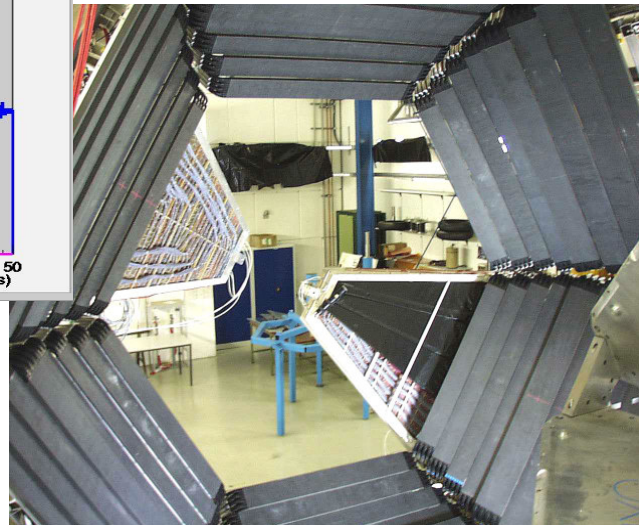
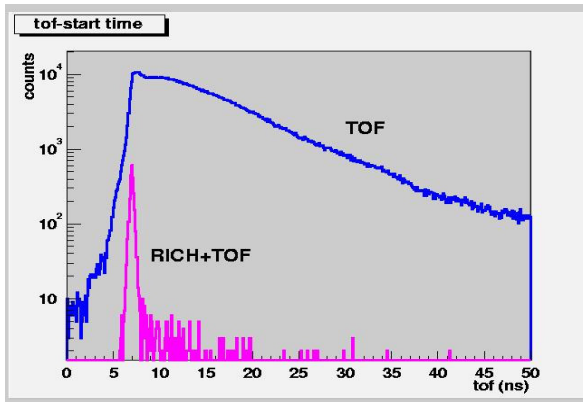

Forward Hodoscope

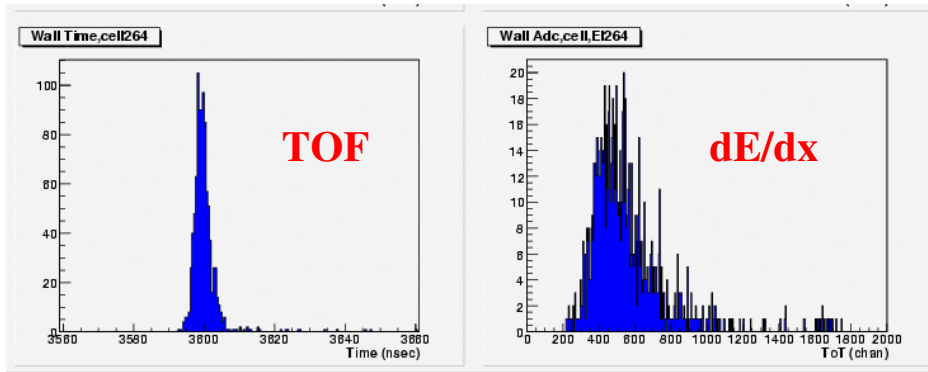

FH covers $0.5^\circ < \Theta < 7^\circ$:

- ✓ 288 scint. Installed (140+64+84)
- ✓ TOF: δt : 90 – 140 ps
- ✓ dE/dx measurement
- ✓ reaction plane in HIC

Elastic pp 3.5 GeV, preliminary

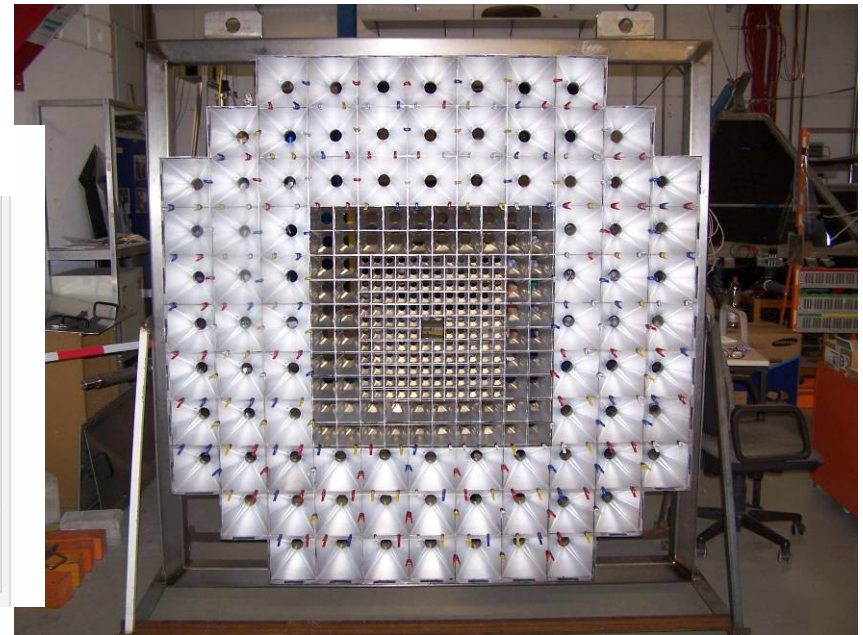
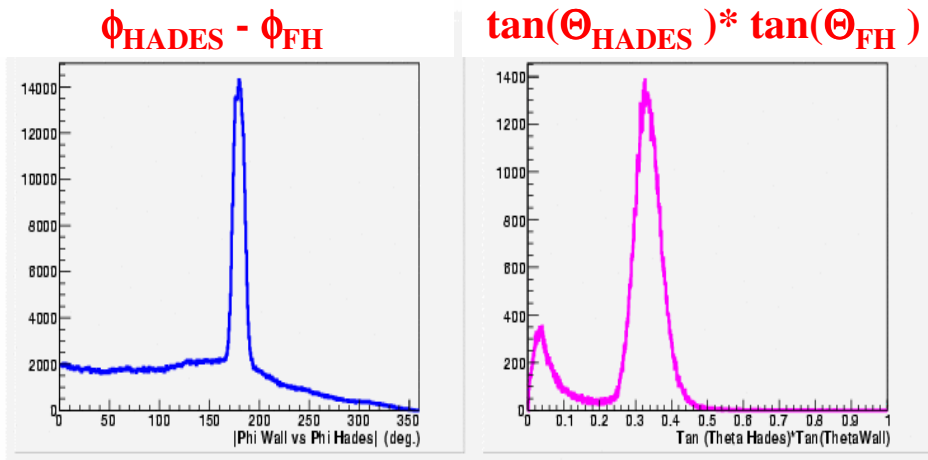

HADES: Commissioning runs (2001)

- November 2001-commissioning run, target=5%

- **C+C 2AGeV** high field 80 mil. LVL1 triggered events ($M_{ch.}>3$)
for DST 50 mil. analysed
outer MDC not used for analysis

- **C+C 1AGeV** low field 7mil. LVL1 tr. evt.

HADES: Experiments

- November 2002: C+C 2 AGeV ^[1] 220 Mevents
56% LVL1 trigger + 44% LVL2 trigger events.
- February 2004: p+p 2.2 GeV 400 Mevents
- August 2004: C+C 1 AGeV 650 Mevents
56% LVL1 trigger + 44% LVL2 trigger events.
- October 2005: Ar+KCl 1.75 AGeV ~1 Gevents
56% LVL1 trigger + 44% LVL2 trigger events.
- May 2006: p+p 1.25 GeV
- **April-May 2007: p+p 3.5 GeV, d+p 1.25 GeV**
- × π^- -induced reactions
- × 2008: time-of-flight upgrade
- × From 2008 on: heavy systems

Dielectron Production in $^{12}\text{C}+^{12}\text{C}$ Collisions at 2A GeV with the HADES Spectrometer,

G. Agakichiev, ..., A. Kugler, ..., P. Tlustý, ..., V. Wagner *et al.* [HADES Collaboration], Phys. Rev. Lett. 98 (2007) 052302

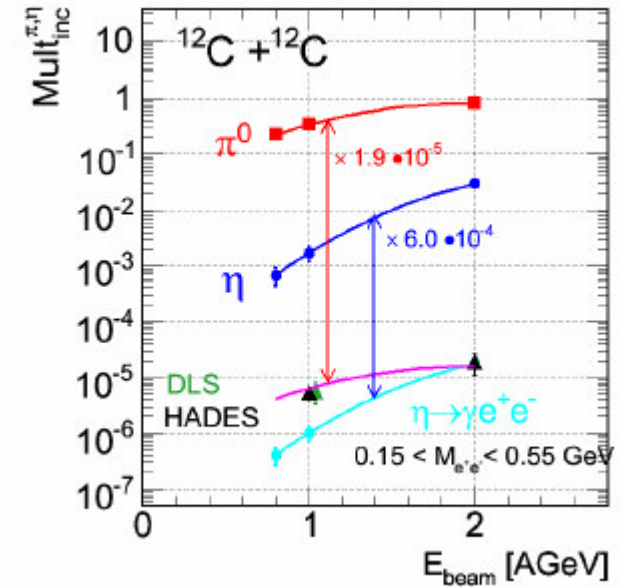
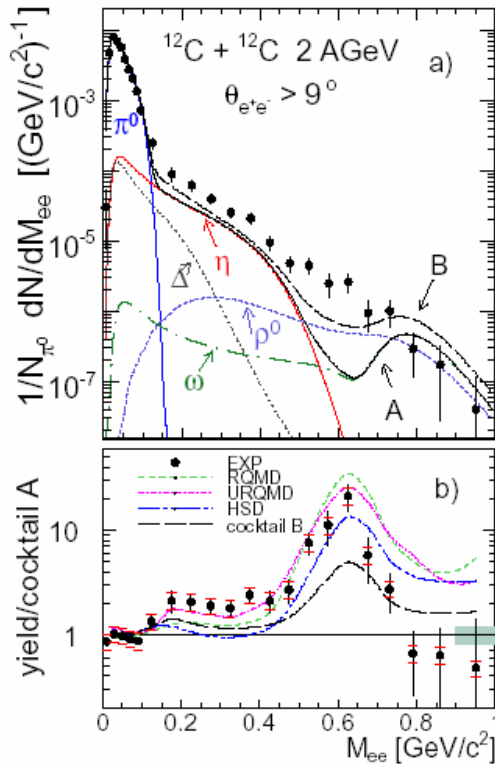

Dielectron yield (corrected for reconstruction efficiencies) in the acceptance of the HADES [15]. In the upper panel (a), the measured yield is compared to a cocktail assuming decay of particles in the vacuum. The cocktail is divided into contributions expected from particles with $t > t_{\text{fireball}}$ (full lines, cocktail A) and particles/resonances with $t < t_{\text{fireball}}$. The sum of both defines cocktail B. In the lower panel (b) the experimental yield is divided by cocktail A to show the relative enhancement above the conventional sources. The various lines display in addition the prediction of microscopic transport models.

Excitation function of the multiplicity of excess pairs (triangles) in the mass range $150 < M_{ee} = \text{MeV}/c^2 < 550$ in collisions compared to light hadron production. The data points are from TAPS (p_0 - full squares, h - full circles), DLS (dielectrons at 1.05 A GeV) and HADES (2.0 A GeV).

A.Kugler, NPI Řež 17

HADES: running experiment

Particles detected in HADES in coincidence with forward going proton in FH



Total Events: 1'809'924'003

HADES beam time Apr07

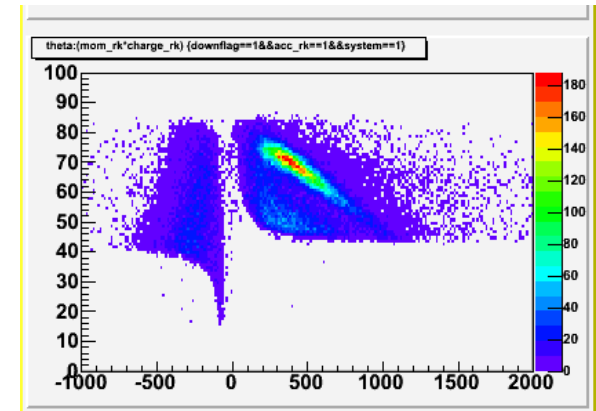
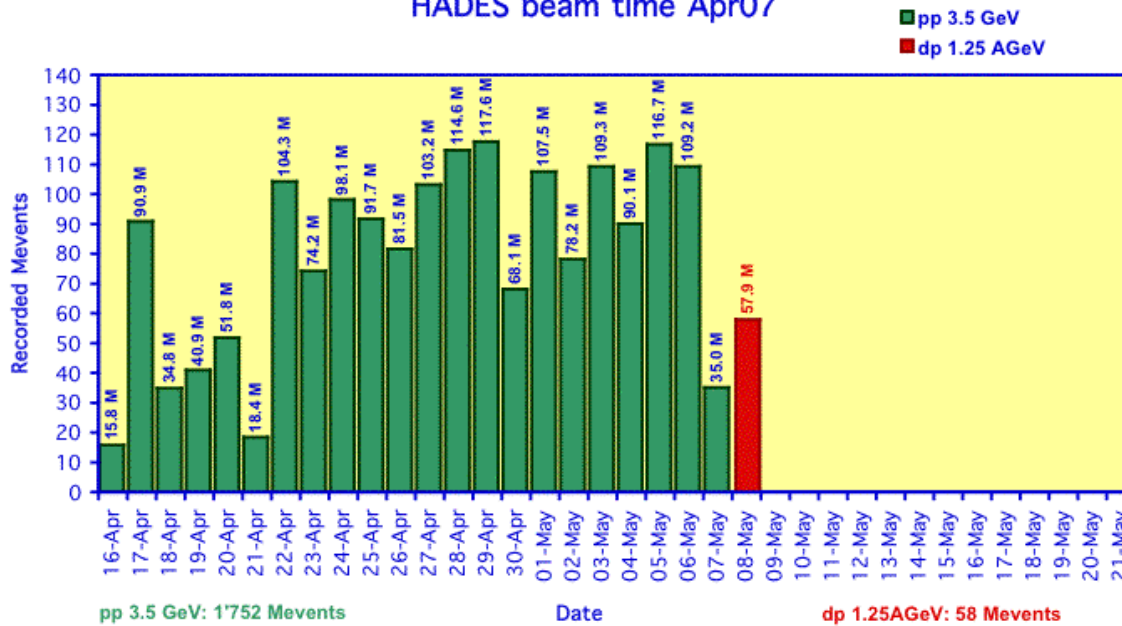

pp (3.5 GeV)->pp η
and
pp (3.5 GeV)->pp ω

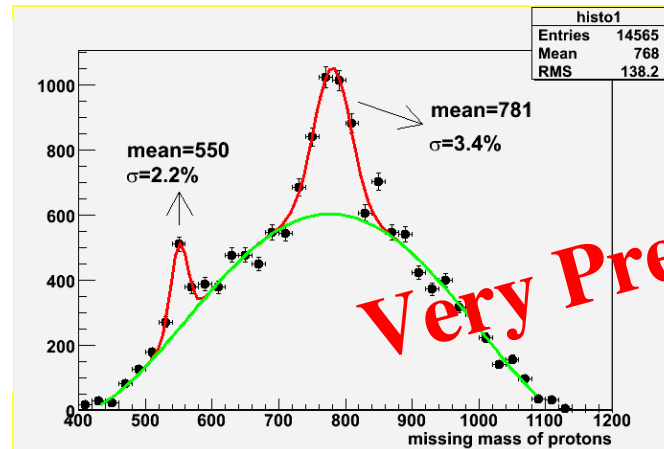

Very Preliminary

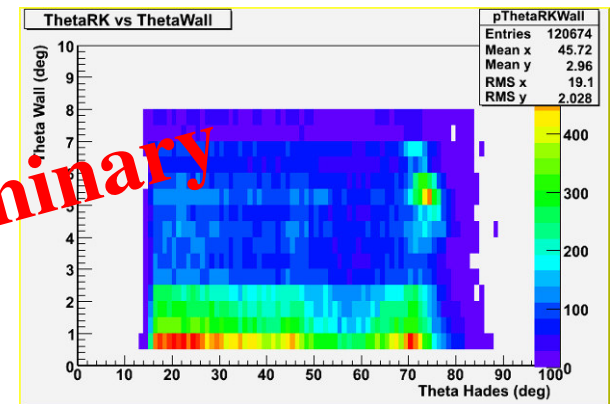

HADES: Results

- **e+e- invariant mass distributions**
 - ✓ C+C @ 2.0 AGeV → final results available
 - ✓ C+C @ 1.0 AGeV → preliminary, final tuning
- **Lepton efficiency verified**
 - ✓ dielectron and hadron channels of π^0 , η
 - lepton efficiency well understood
- **Hadrons**
 - ✓ Kaon identification → limited by the time resolution
 - ✓ Pion transverse mass spectra
 - agreement with KaoS and TAPS

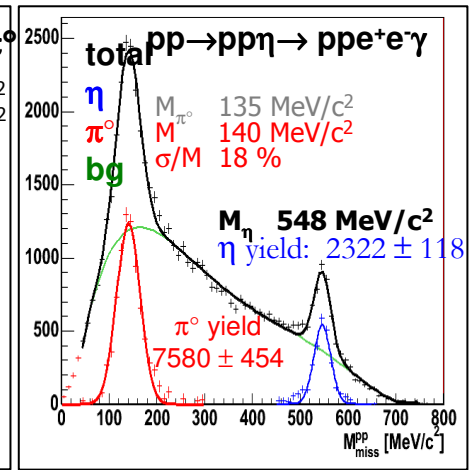
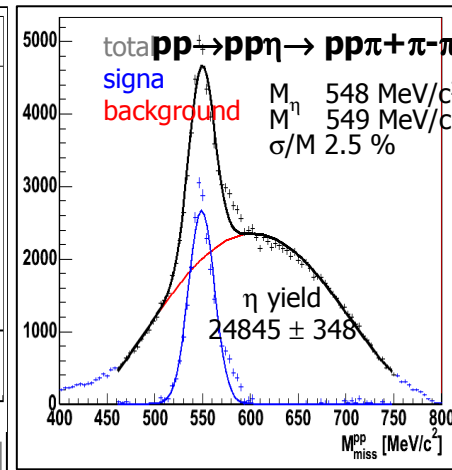
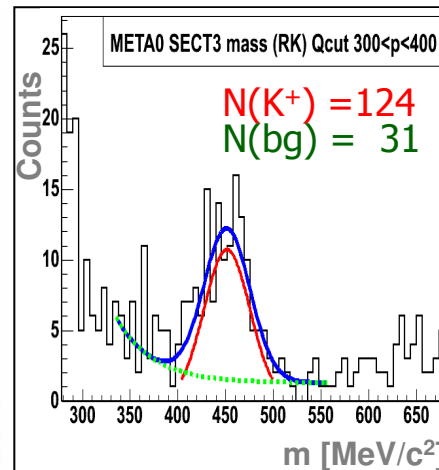
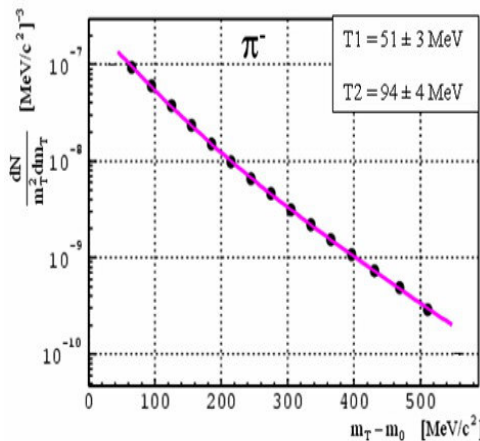
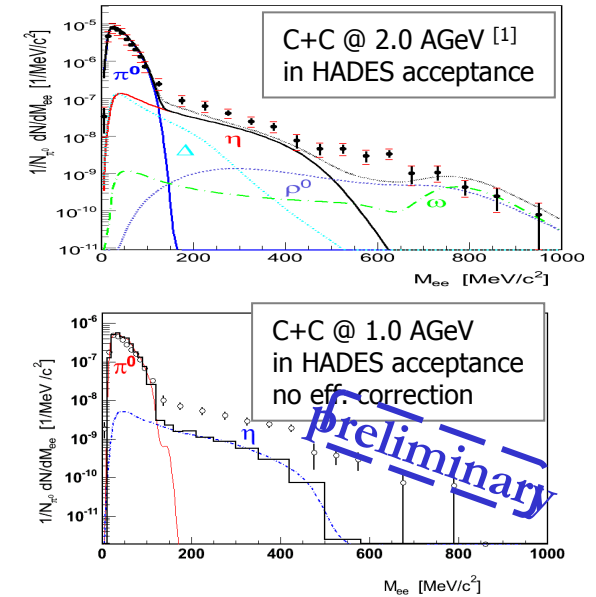

HADES upgrade: Simulations

Simulation results [1]

- Occupancy consideration (hadrons)
 - ✓ from C+C@2AGeV to Au+Au@2AGeV
increase by a factor of 16
 - ✓ from Au+Au@2AGeV to Au+Au@8AGeV
increase only by a factor of 2
- Acceptance for leptons (see table)

e+e- pairs from direct decay of rho meson		
System	HADES acceptance	N detected / coll.
C+C @ 2AGeV	33 %	2.7×10^{-7}
C+C @ 8AGeV	22 %	$134.0 \times 10^{-7}(50)$
Au+Au @ 8AGeV	21 %	$739.0 \times 10^{-7}(230)$

- Requirements for SIS18 and SIS100 are similar.

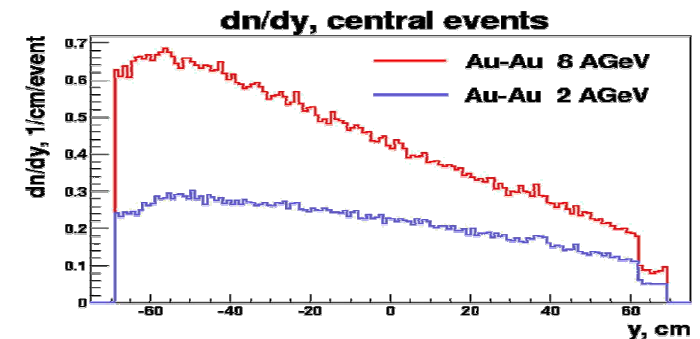
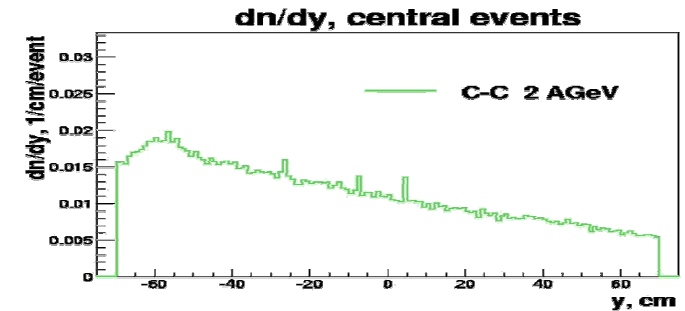
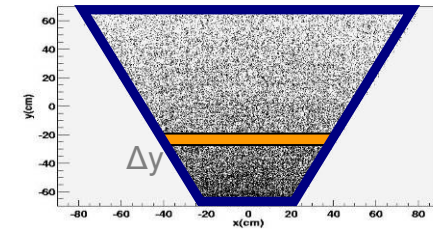

1. A.Kugler et al. Proceedings of XLIV International winter meeting on Nuclear Physics, Bormio 2006, Vol.125,p.282-6

HADES upgrade: Tofino replacement by RPC

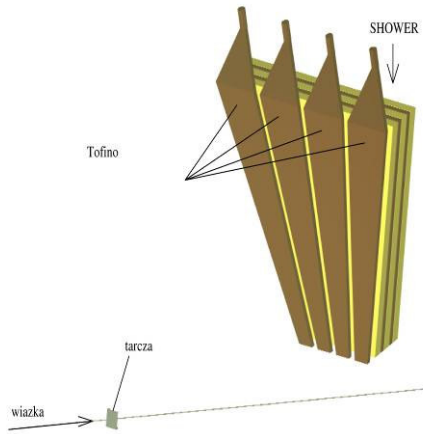

TOFINO $18^\circ < \Theta < 45^\circ$

✓ $6 \cdot 4 = 24$ scintillators in total

✓ $\delta t \approx 0.35$ ns

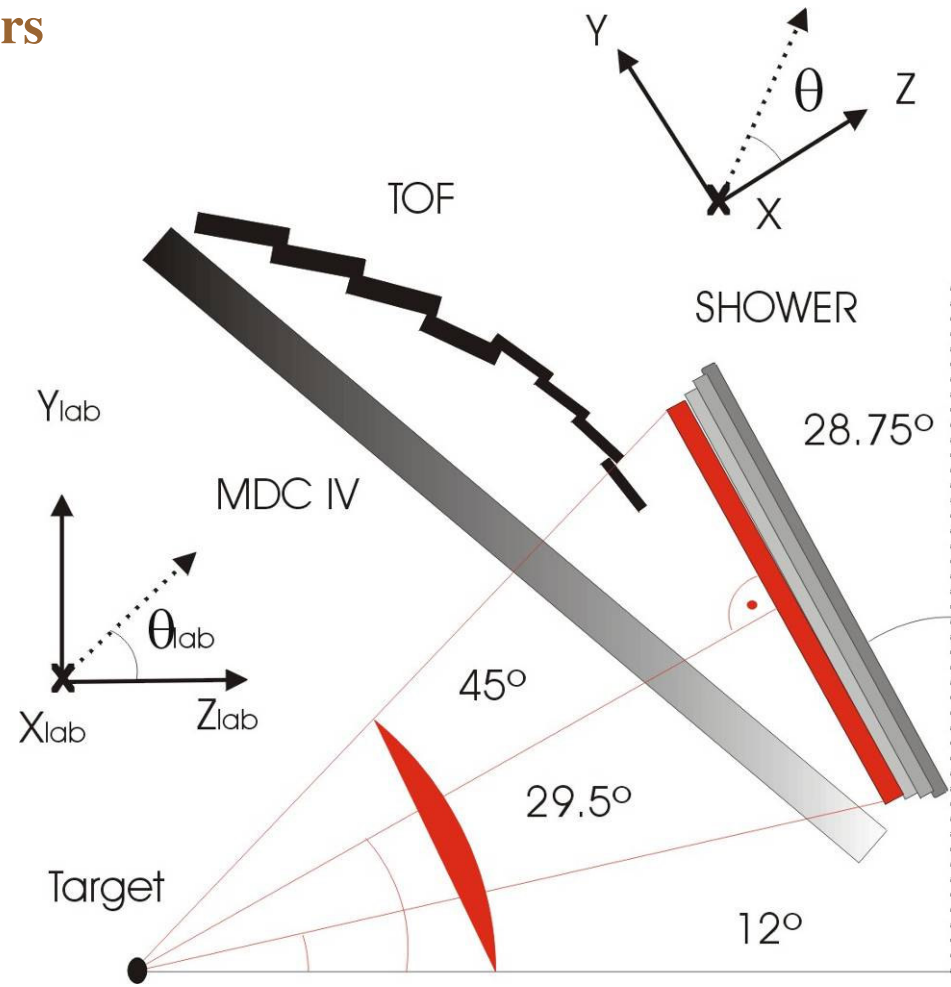
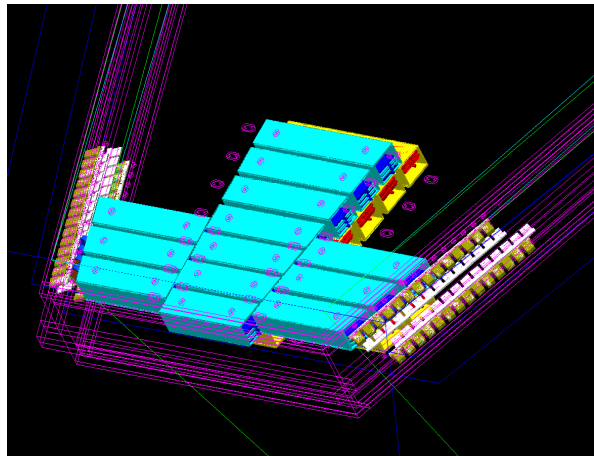

Hades upgrade projects - summary

List of projects

- EU-FP6 Construction Contract
 - ✓ RPC - Resistive Plate Chamber
 - Time res. 50-80ps
 - Granularity needed for heavy systems (Au+Au)
 - ✓ **Forward Wall**
 - θ range 0.2 – 7 degrees, reaction plane determination
 - ✓ DAQ-Upgrade (CPUs, Event Builder, VME crates, MUv2)
 - goal 20kHz for Au+Au LVL1

- BMBF (Bundesministerium für Bildung und Forschung)
 - ✓ MDC Readout / Trigger (Frankfurt)
 - ✓ RICH Readout / Trigger (München)
 - ✓ LVL2 Compute Node (Gießen)
 - ✓ Pion Hodoscopes (Gießen)
 - ✓ Rebuilding of the 1st MDC layer, 6 chambers (Rossendorf)

In 2008: HADES ready for **heavy system experiments**

Stage 2
(2011- 2013)

Proton-antiproton physics

- QCD studies with protons and antiprotons
- Precision studies with antiproton beams addressing fundamental symmetries and interactions

•**upgraded HADES**
(up to 10 GeV/N)

CBM prototype detector tests

J.Eschke

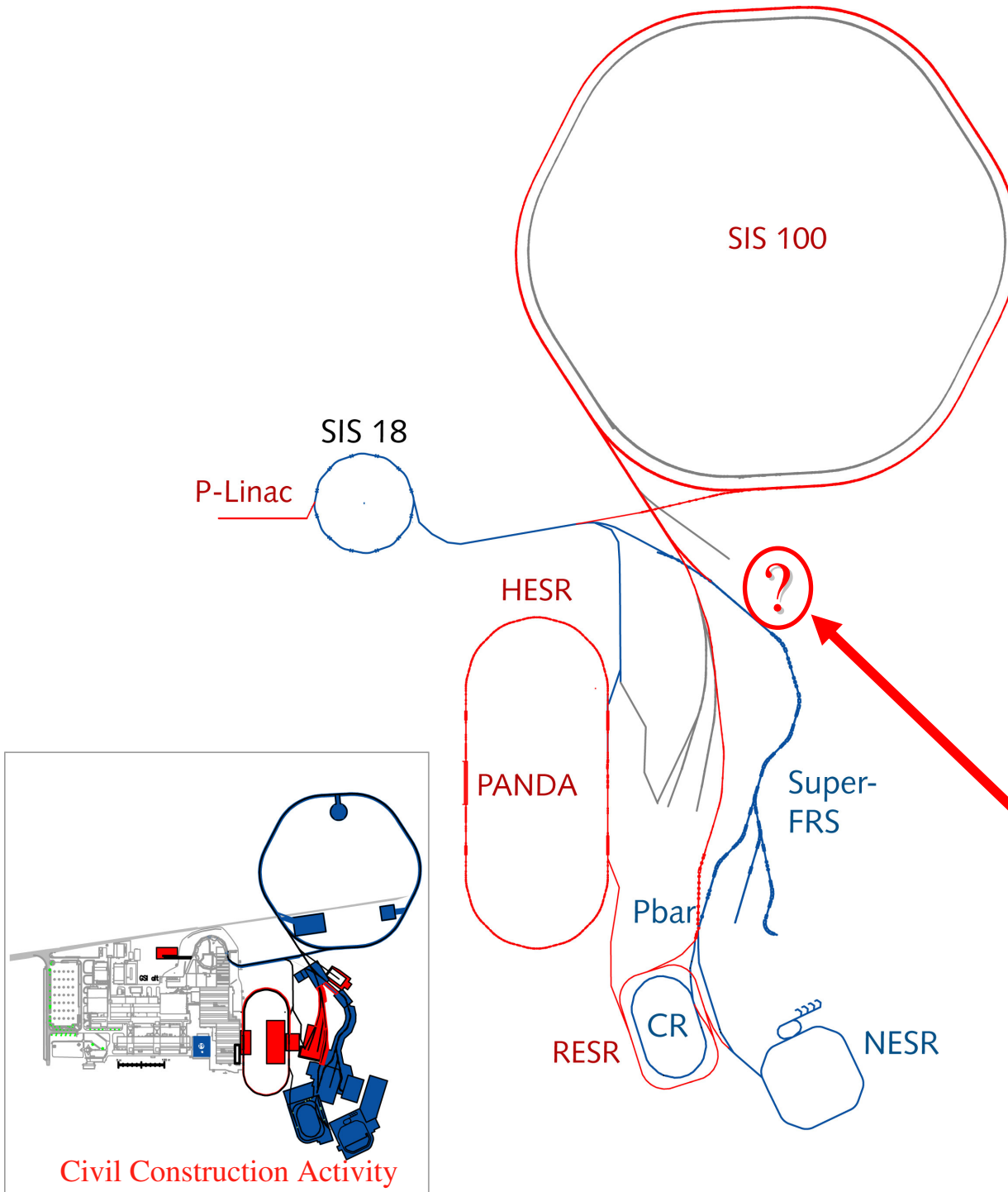

HADES, papers in referred journals ...

Publikace

- G.Agakichiev, ... A.Kugler et al. : *Dielectron Production in 12C+12C Collisions at 2A GeV with the HADES Spectrometer*, Phys. Rev. Lett. 98, 052302 (2007)
- J.Pietraszko, ... A.Kugler et al.: *Dielectron production in C+C and p + p collisions with HADES*, Int.Journal of Modern Physics A (2006)
- W. Przygoda, ..., A.Kugler et al: *HADES experiment: Di-lepton spectroscopy in p + p (2.2 GeV) and C + C (1 and 2 A GeV) collisions*, Acta Physica Polonica B37 (2006) 139-151
- R.Holzmann, ... A.Kugler et al.: *Measurement of the di-electron mass spectrum in 12C+12C collisions at 2 AGeV by HADES* Nucl.Phys.A774:727-730,2006
- P.Salabura,... A.Kugler et al.: *PROBING OF IN-MEDIUM HADRON STRUCTURE WITH HADES*. Nucl.Phys.A749:150-159,2005
- J.Bielcik,... A.Kugler et al.: *DILEPTON ANALYSIS IN THE HADES SPECTROMETER FOR C + C AT 2-A-GEV*. J.Phys.G31:S231-S237,2005
- J.Otwinoski,..A.Kugler et al: *DILEPTON ANALYSIS IN THE HADES SPECTROMETER FOR C-12 + C-12 AT 2-A-GEV*. Int.J.Mod.Phys.A20:602-605,2005
- T.Eberle..., A.Kugler et al.: *DI-ELECTRON MEASUREMENTS IN C + C REACTIONS AT 2-GEV-A WITH HADES*, Nucl.Phys.A752:433-438,2005
- A.Kugler et al.: *CHARGED HADRONS AND LEPTONS IDENTIFICATION AT HADES*. Acta Phys.Slov.54:375-384,2004
- P.Salabura,... A.Kugler et al.: *STUDYING IN-MEDIUM HADRON PROPERTIES WITH HADES*. Acta Phys.Polon.B35:1119-1129,2004
- P.Salabura,... A.Kugler et al.: *STUDY OF E+, E- PRODUCTION IN ELEMENTARY AND NUCLEAR COLLISIONS NEAR THE PRODUCTION THRESHOLD WITH HADES*. Prog.Part.Nucl.Phys.53:49-58,2004
- A.Kugler et al. *Particle identification at HADES*. Nucl.Phys. A 734 (2004) 78
- A. Kugler : High Acceptance Di-Electron Spectrometer - Tool for Study of Hadron Properties in the Nuclear Medium, Czech. Journ. Phys., 50/S2, 2000, p.72.
- Rabin NV, ..., Kugler A, Marek T, Pleskac R, Taranenko A, Tikhonov A, Tlusty P, et al. A time-of-flight measurement system for the HADES wide-aperture dielectron spectrometer, Instrum. Exp.Techn. 43: (4), 2000, p.435
- Agodi C, ..., Kugler A, ... Marek T, ..., Pleskac R, ... Suk M, Taranenko A, Tlusty P, ... Wagner V, Zovinec D: *The HADES time-of-flight wall*, NUCL INSTRUM METH A 492: (1-2) 14-25 OCT 11 2002.
- C.Agodi,... A.Kugler,... T.Marek,... R.Pleskac,... A.Taranenko, A.Tikhonov, P.Tlusty..., The Time Of Flight Wall for the HADES Spectrometer, IEEE Transactions on Nuclear Science, Vol.45, No 3., 1998, p. 665-669.

HADES, conferences, workshops ...

Proceedings, reports

- A.Kugler: *HADES at SIS100*, proceedings of the XLIV International Winter Meeting on Nuclear Physics, Bormio , 2006, p.282-6.
- P. Tlustý, A.Kugler, R.Pleskač, V.Wagner, M.Suk, S.Hlaváč, D. Žovinec: *Electron-positron pair production in Nuclear Matter - First Data from HADES*, Sbornik 14 konf.českých a slov. Fyziků, Plzeň 2002
- A.Kugler, *FYZIKA SRÁŽEK TĚŽKÝCH IONTŮ -NOVÝ SMĚR JADERNÉ FYZIKY*, zvaná přednáška na 13. konferenci slovenských a českých fyziků, konané v dnech 23. až 26. srpna 1999 na Technickej univerzite vo Zvolene, zbornik prednasok, Zvolen, 1999, 48-51.
- A.Kugler, A.Tikhonov, P.Tlustý, A.Taraněnko, V.Wagner, R.Pleskač, *In-Medium Modifications of Hadron Properties in Relativistic Heavy Ion Collisions*, Acta Polytechnica, Vol.38, 1998, 47-48.
- P.Tlustý, A.Tikhonov, A.Kugler, T.Marek, A.Taraněnko, R.Pleskač, *The Time-Of-Flight Detector for HADES*, Acta Polytechnica, Vol.38, 1998, 49-52.

Conferences, workshops

- Bormio winter meeting, 22-27 leden, 2001, Bormio, P.Tlustý *Simulation of azimuthal distributions of di-lepton pairs in the HADES experiment*
- HADES Collaboration Meeting X, 28 únor - 2 března, 2001,GSI , P.Tlustý *Simulation of azimuthal distributions of di-lepton pairs in the HADES experiment*
- HADES Collaboration Meeting XI, 11 - 14 dubna, 2002, Smolenice, P.Tlustý *TOF detector performance*
- 14 konf.českých a slov. Fyziků, Plzeň 2002, P. Tlustý *Electron-positron pair production in Nuclear Matter - First Data from HADES*
- VIII.Int.Conference Nucleus-Nucleus collisions Moscow, Russia, June 17-21, 2003, A.Kugler - *Particle identification at HADES*
- Int.Conference RNP2003, Stara Lesna, August 2003 ,A.Kugler - *Particle identification at HADES*
- XIII HADES Collaboration Meeting Nicolosi, Italy, December 3rd - 6th, 2003, J. Novotný *Simulations of measurement of dielectrons from C+C at 8 A GeV by HADES*

Basic Research -CBM Detector

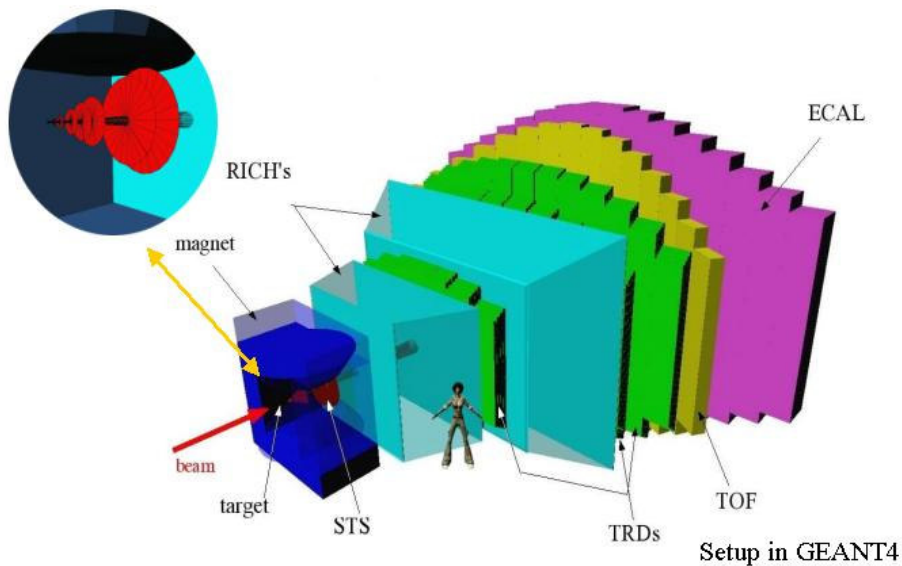
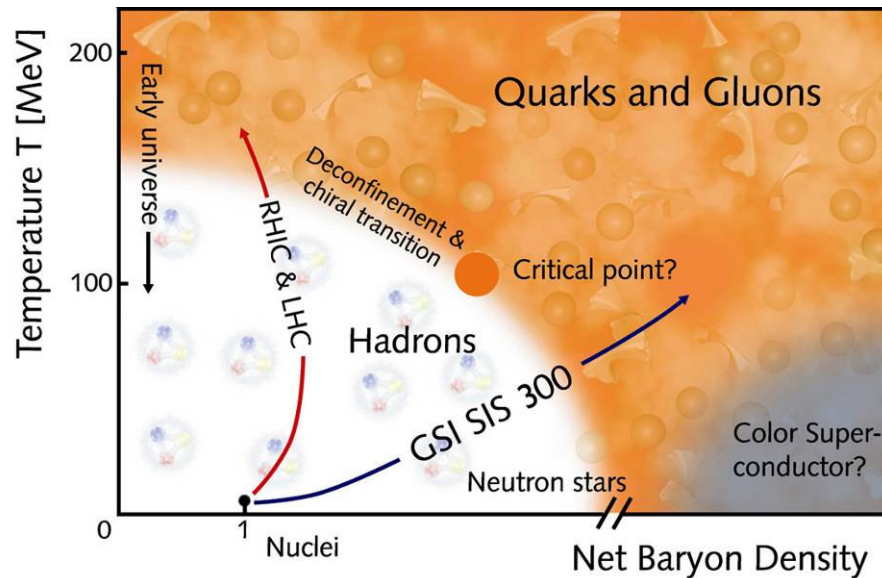

- Inside the dipole magnet gap are the target and a 7 plane Silicon Tracking System (STS) consisting of pixel and strip detectors.
- The Ring Imaging Cherenkov detectors (RICH) have different radiators for the detection of electrons (first RICH) and mesons (second RICH).
- The Transition Radiation Detector (TRD) arrays measure electrons with momenta above 1 GeV ($\gamma = 2000$).
- The TOF stop detector consists of Resistive Plate Chambers (RPC).
- The electromagnetic calorimeter (ECAL) measures electrons, photons and muons.

Au+Au @ 25A GeV Dilepton and D mesons (simulation)

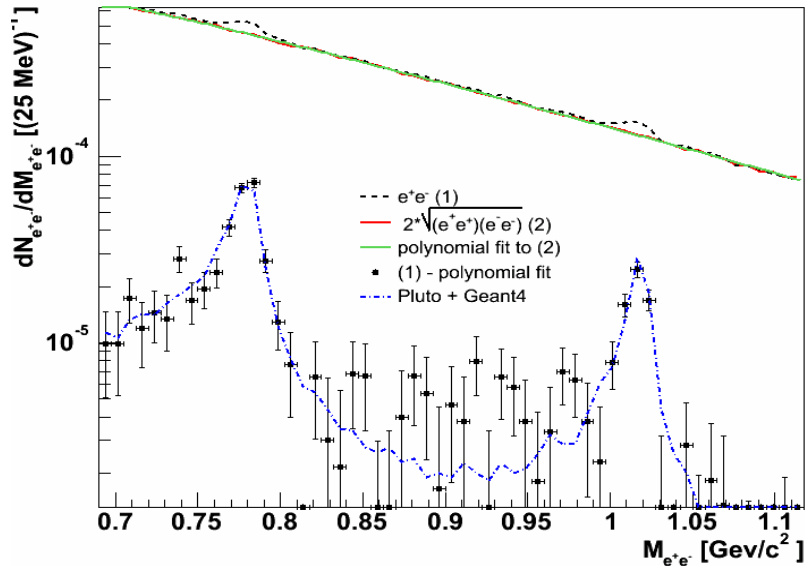

D mesons will be detected via their weak decay into charged pions and kaons. The mean lifetime of the D^0 mesons is $c\tau = 124 \mu\text{m}$, which means that the secondary vertex needs to be determined with a resolution of less than $\sim 50 \mu\text{m}$.



- Electron pair mass spectra:
- all pairs
- **combinatorial background**
- subtracted spectrum (full dots)
- vector meson signal input (blue dashed-dotted line).

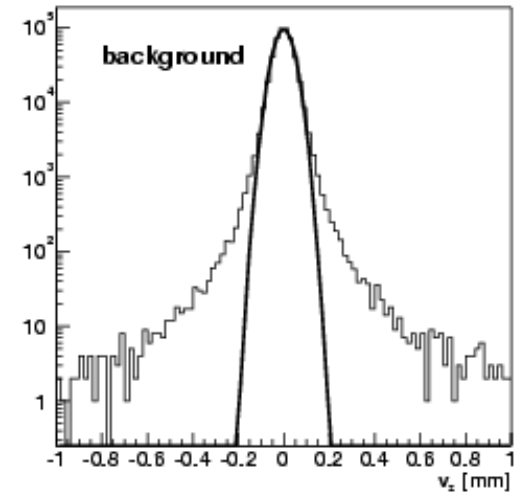
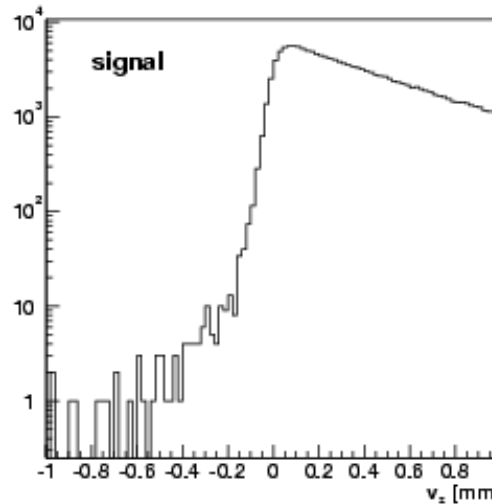

Thank you for your attention